

JAKI

Lead the smart flow

Automatic Control Valve

960 Series Water Control
Flow - Pressure - Level Control

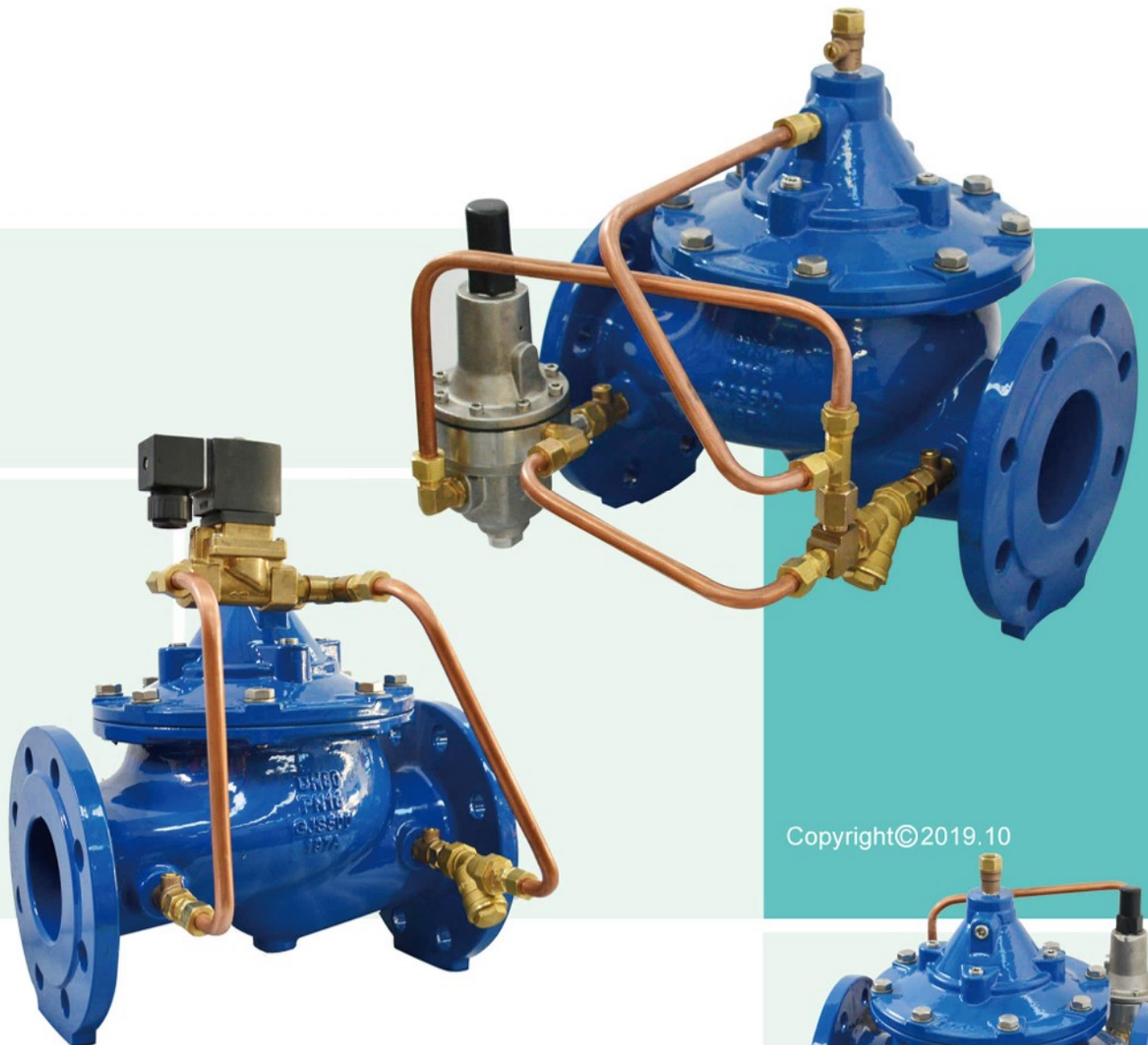

Copyright©2019.10



Jakiflow Corporation

No.15, Ln.582, Zhangcao Rd.,
Changhua City 500,Taiwan

www.jakiflow.com

TEL:+886 4 761 8111

FAX:+886 4 7616611

sales@jakiflow.com

Model 960 Series

Full Port Ductile Iron Single Chamber Main Valve

The JAKI model 960 Main Valve is a basic valve for JAKI automatic control valves. It is a hydraulically operated, diaphragm actuated globe-type body valve.

The valve has three major components: body, cover and diaphragm assembly. The diaphragm assembly is the only moving part within the valve allowing it to open, close, or regulate as commanded by the pilot control system. The cover forms a sealed chamber above the diaphragm to separate operating pressure from line pressure.

Valve Design Features

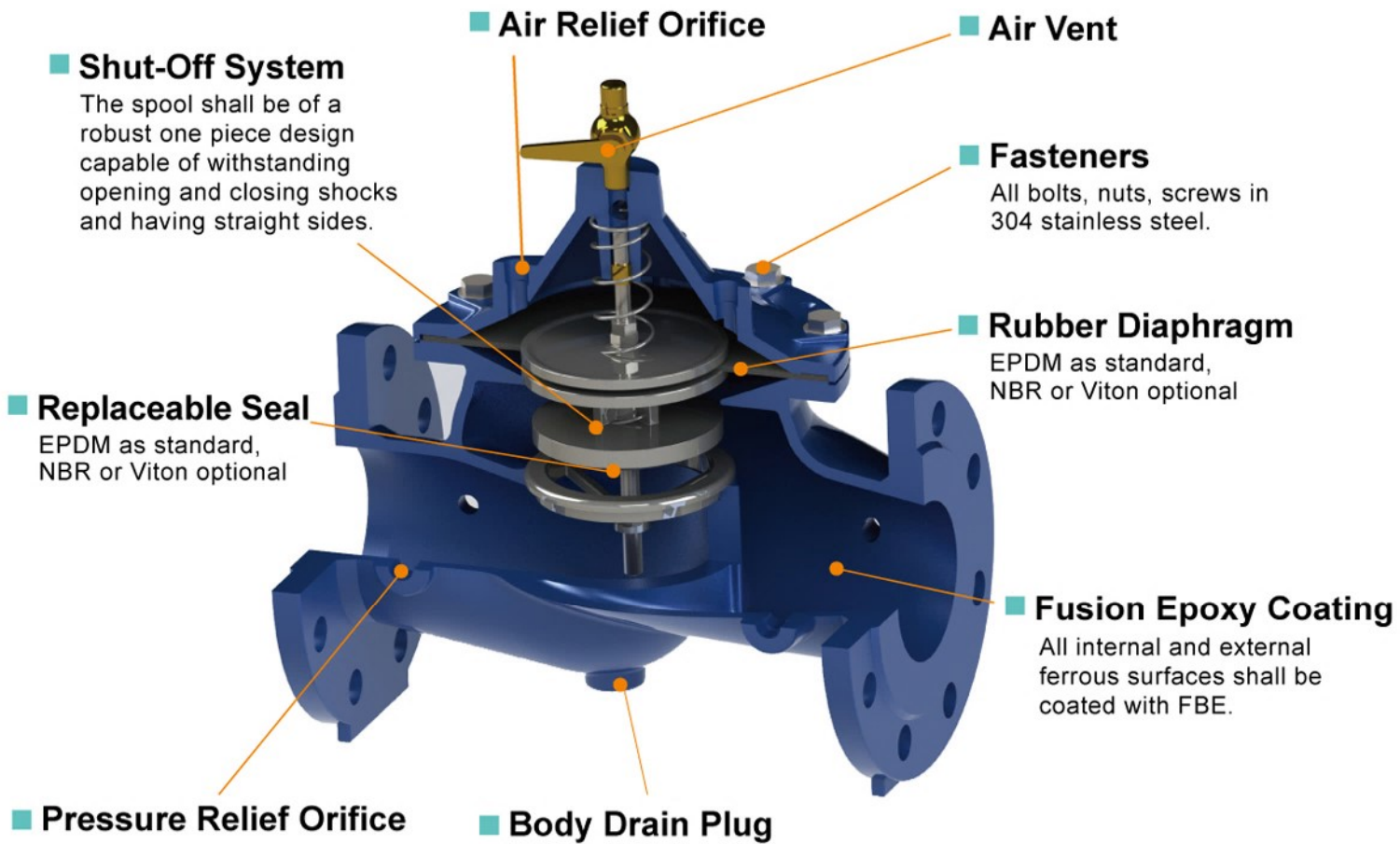

Principle of Operation

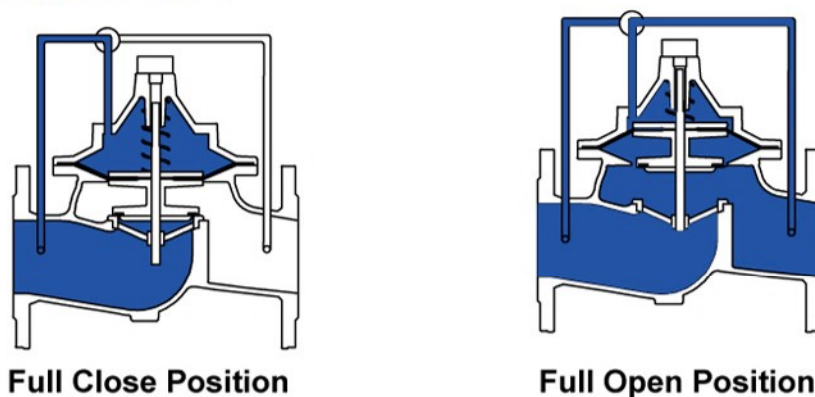

Standard Specifications

Body Configurations: Globe pattern

Valve Size: 50mm ~ 300mm

Pressure Rating: PN16

Flange Adaptability: EN1092 PN10/16, JIS 10K

Inspection & Testing: EN12266-1

Operating Temperature

Buna-N: max. 160°F

EPDM: max. 240°F

Viton: max. 350°F

Item	Description	Material
1	Body/Cover	Ductile Iron
2	Stem	AISI 316
3	Seat/Seat Plate	Stainless Steel
4	Spool/Diaphragm Plate	Stainless Steel
5	Seat Seal	EPDM
6	Diaphragm	EPDM
7	Spring	Stainless Steel
8	Fasteners	Stainless Steel

Dimensions - mm

DN	A	B	C
50	230	284	199
65	290	299	199
80	310	300	300
100	350	330	220
125	400	368	243
150	480	423	281
200	600	520	248
250	730	562	360
300	850	747	515

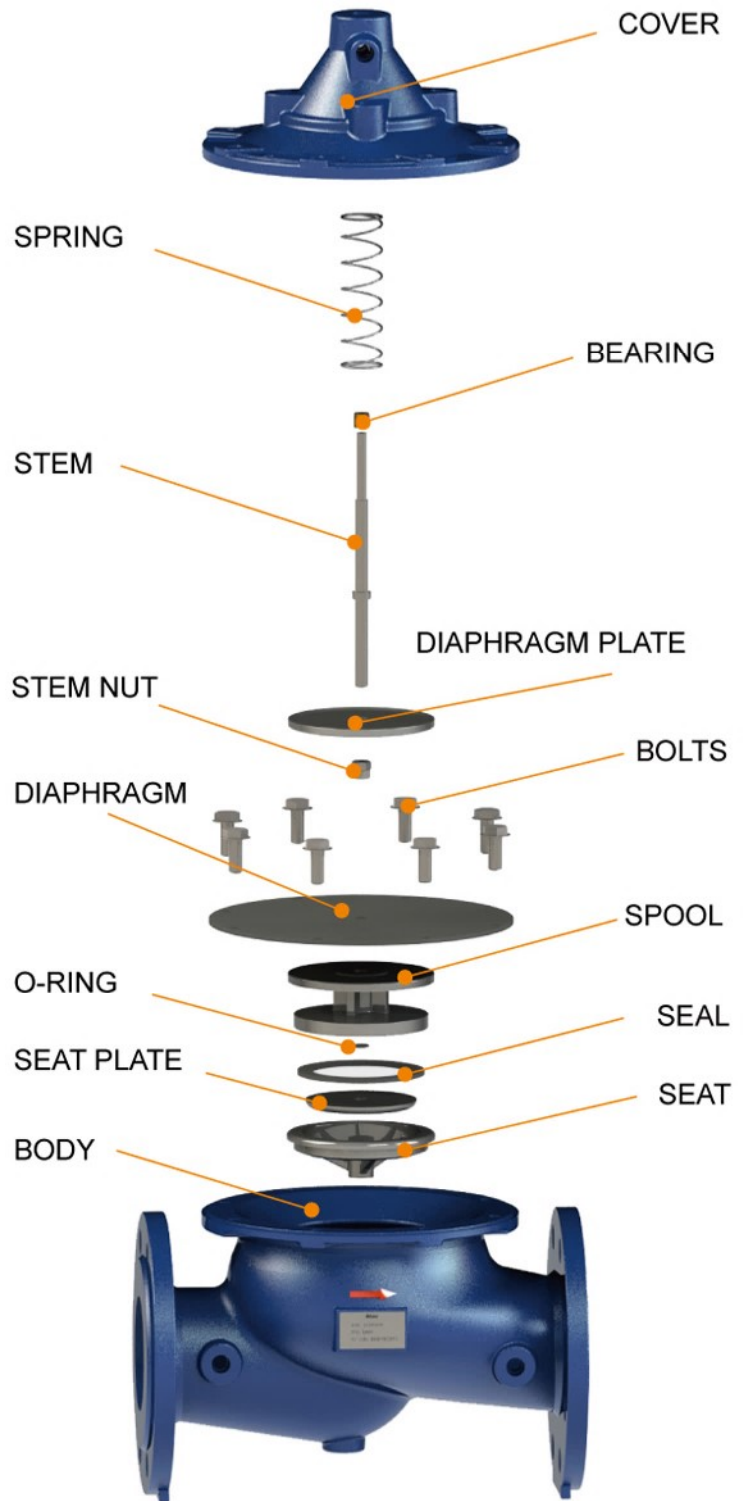
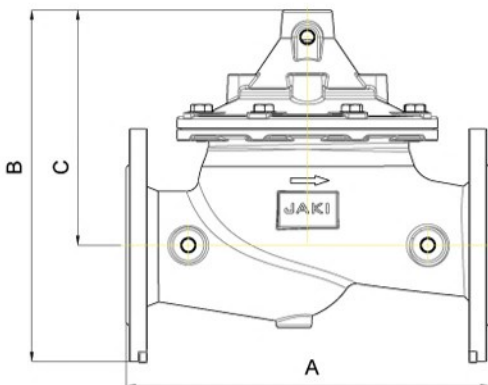

Design Change

In order to follow the JAKI commitment to continuous improvement, we reserve the right to revise or modify product and performance without prior notice.

Model 964

Pressure Reducing Valve

The Pressure Reducing Valve is designed to automatically reduce a high upstream (inlet) pressure to a lower constant downstream (outlet) pressure at a preset pressure, regardless of changing and/or varying upstream pressure and flow rates.

The Model 964 is a pilot controlled valve and normally open when pressure is applied to the valve inlet. When flow is required, the pilot valve senses downstream pressure and reacts immediately to reposition the valve as the outlet pressure tends to increase or decrease with varying demand.

The Pressure Reducing Valve is used mostly for many application of Water Systems, Municipal, Industrial, Buildings and Irrigation.

Pilot Control Valve

PRV Pressure Reducing Pilot valve is a direct acting, spring loaded, diaphragm type valve that operates hydraulically and designed to maintain a pre-set pressure. It is normally held open by the force of the adjustable spring setting above the diaphragm.

Sizing Pressure Reducing Valves

A properly sized valve prevents noisy operation or premature valve failure. Over sizing pressure reducing valves can lead to problems such as wire draw under low flow conditions. The pressure reducing valves should be selected based on the flow and pressure ranges. For more detail, please consult JAKI.

Valve Size	DN50	DN65	DN80	DN100	DN125	DN150	DN200	DN250	DN300
Flow Rate									
Minimum m ³ /h	0.50	1.15	1.15	3.45	9.15	9.15	13.70	24.70	50.60
Maximum m ³ /h	36	45	45	92	165	165	365	715	1001

Schematic Assembly

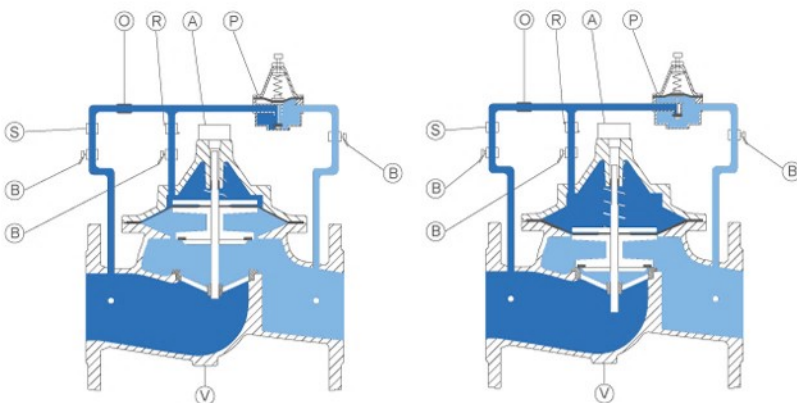

Part List		Material
V	Main Valve	Ductile Iron
P	Pilot Valve	Brass/Stainless Steel
A	Air Vent	Brass
R	Flow Control	Brass/Stainless Steel
O	Orifice	Stainless Steel
S	Y-Strainer	Brass
B	Ball Valve	Brass
Tubing & Fitting		Brass/Stainless Steel

Open Position

When the downstream pressure is lower than the pilot setting, the pilot valve (P) automatically opens, by releasing line pressure from the cover chamber to move the main valve to the open position.

Closed Position

When the downstream pressure rises above the set-point, the pilot valve (P) throttles, the cover pressure is increased, causing the main valve to the fully closed position and provides drip-tight sealing.

Model 965

Backpressure Sustaining Valve

In-Line Installation

The valve throttles to sustain minimum preset, upstream (back) pressure regardless of fluctuating flow or varying downstream pressure.

The Model 965 is a pilot controlled valve and the pilot senses the upstream pressure through a connection to the valve inlet. The pilot valve reacts to small changes in pressure to control the valve position by modulating the pressure above the diaphragm.

Should the upstream pressure fall below the set-point, the valve will close or modulate to ensure that the set-point is maintained. Should upstream pressure exceeds the pilot setting, the pilot releases accumulated pressure causing the main valve to modulate open.

Model 966

Pressure Relief Valve

Circulation Installation

The valve opens rapidly when the inlet pressure meets or exceeds the pilot pressure setting to relieve damaging overpressure and closes smoothly at an adjustable speed.

The pilot valve shall be normally closed and the pilot remains closed when the upstream is lower than the set-point. When inlet supply pressure exceeds the pilot setting, the pilot opens to relieve the cover pressure which opens the main valve.

The model 966 Pressure Relief Valve protects against excessive pressure in pump stations, distribution systems, and transmission mains by opening when the inlet pressure higher than a preset value and discharges high-pressure water to waste, pump, suction, or a zone of lower pressure.

Typical Installation

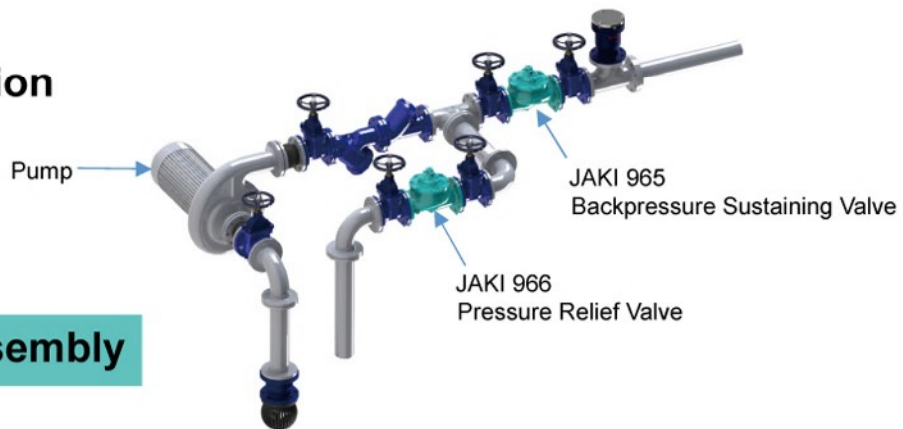

Schematic Assembly

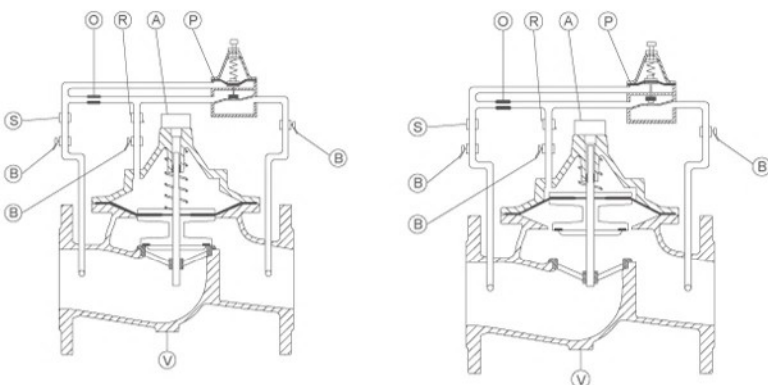

Part List		Material
V	Main Valve	Ductile Iron
P	Pilot Valve	Brass/Stainless Steel
A	Air Vent	Brass
R	Flow Control	Brass/Stainless Steel
O	Orifice	Stainless Steel
S	Y-Strainer	Brass
B	Ball Valve	Brass
Tubing & Fitting		Brass/Stainless Steel

Model 967

Float Valve

On-Off Action: The valve is designed to open fully when the liquid level reaches a preset low point and closed drip-tight when the level reaches a preset high point. Non-modulating float valve is commonly mounted above the high water level in a tank.

Modulating Action: The valve controls to maintain a constant water level, regardless of variation in supply or demand. Pilot operated float valve is used to the water level in ground storage tank, reservoirs or basins by closing to prevent overflow and opening to refill when water level recedes.

Schematic Assembly

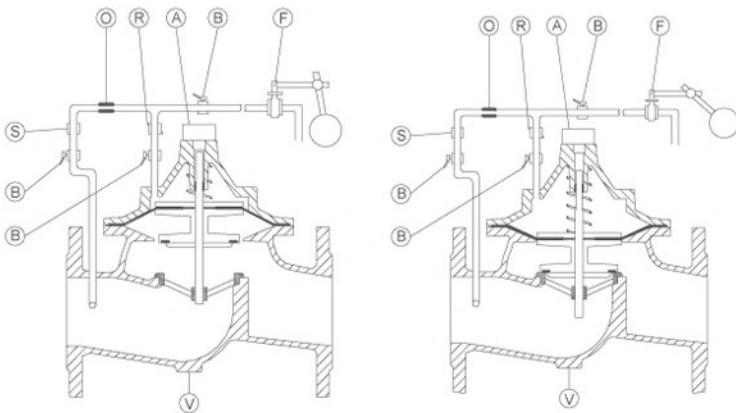

Part List		Material
V	Main Valve	Ductile Iron
F	Float Control	Brass
A	Air Vent	Brass
R	Flow Control	Brass/Stainless Steel
O	Orifice	Stainless Steel
S	Y-Strainer	Brass
B	Ball Valve	Brass
Tubing & Fitting		Brass/Stainless Steel

Model 968

Hydraulic Check Valve

The valve is a non-modulating valve, two position valve, fully open and close at controlled rate through a check valve and manually adjustable speed control (needle valve) to provide for smooth operation and reduce pressure surges.

The Hydraulic Check Valve shall open to permit normal forward flow when the upstream (inlet) pressure is higher than the downstream (outlet) pressure. The valve shall close to prevent reverse flow when the downstream (outlet) pressure is higher than the upstream (inlet) pressure.

Schematic Assembly

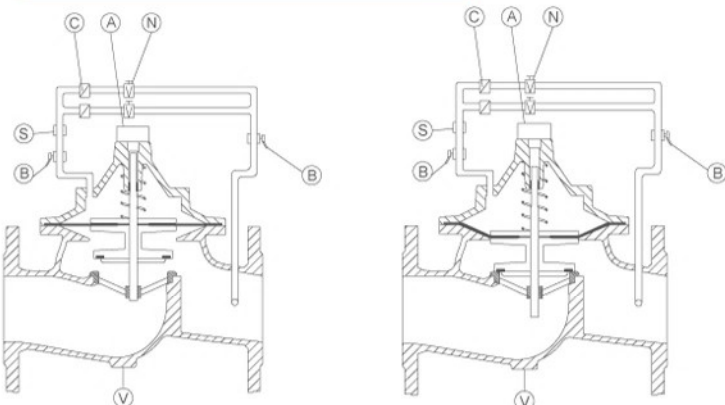

Part List		Material
V	Main Valve	Ductile Iron
N	Needle Valve	Brass/Stainless Steel
A	Air Vent	Brass
C	Check Valve	Brass/Stainless Steel
S	Y-Strainer	Brass
B	Ball Valve	Brass
Tubing & Fitting		Brass/Stainless Steel